



四軸破碎機
Quad Shredder

YG Series

English

Reliable & Professional Recycle-Equipment Manufacturer.



詠興機械
YUNG HSING MACHINE

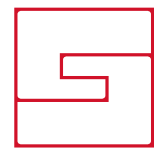

詠固精密
YUNG GU MACHINE

YG Series

Specification

YG Series Quad Shredder is a powerful machine, eliminate the disadvantages in traditional crusher to low-noise and long-time working. Especially for the unusual objects, bakelite, woods, wires & cables, rubbers, aluminum cans etc...To associate the screeners is able to reach the final size as requirement directly.

- YG26 —— p.3
- YG32 —— p.4
- YG38 —— p.5
- YG44 —— p.6
- Shafts and cutters exploded view —— p.7-8

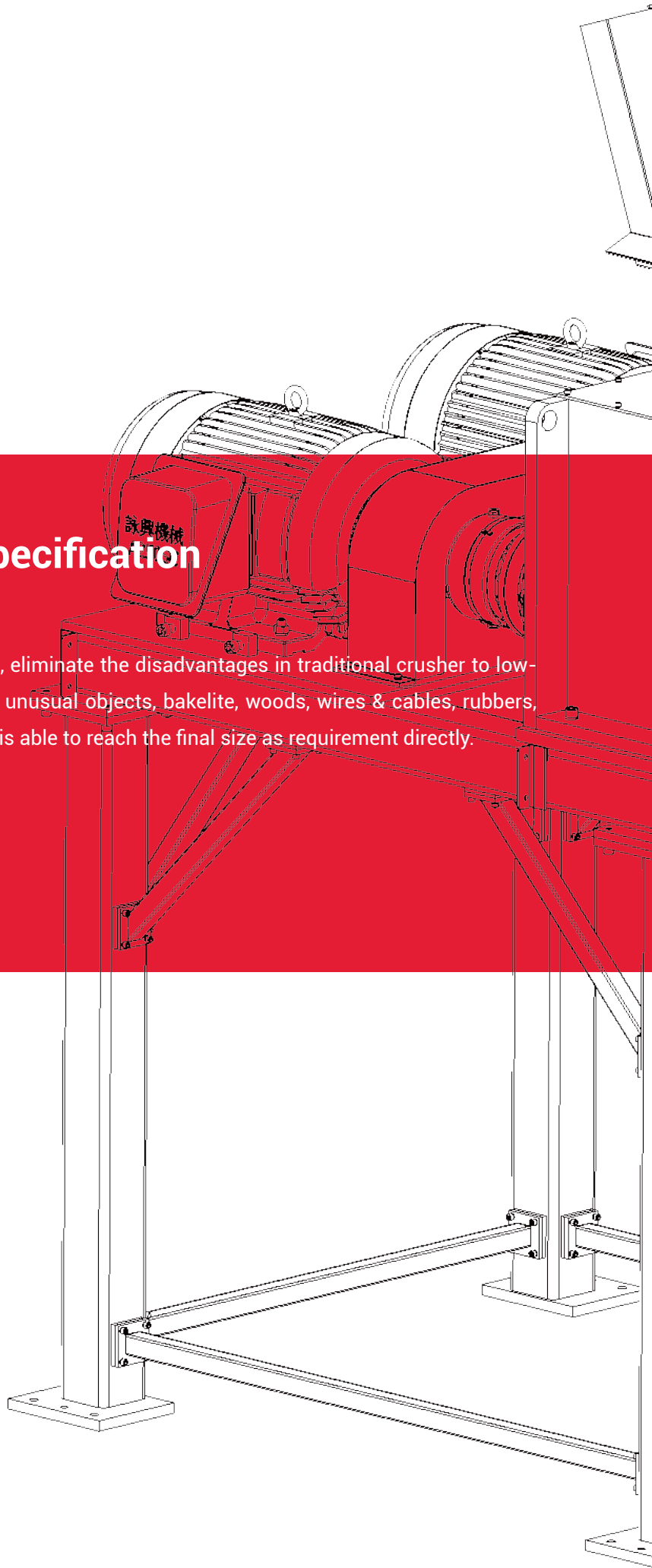

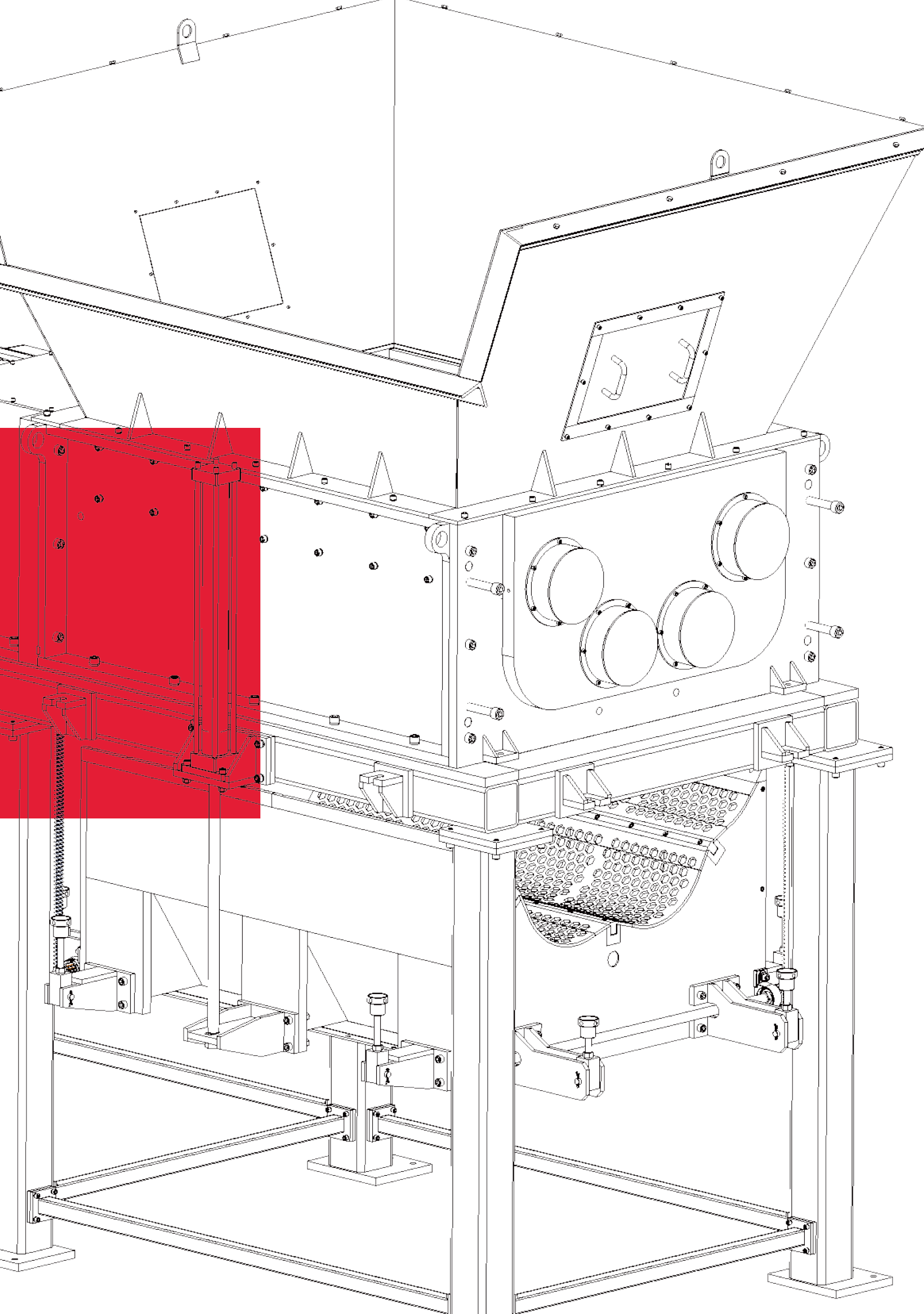

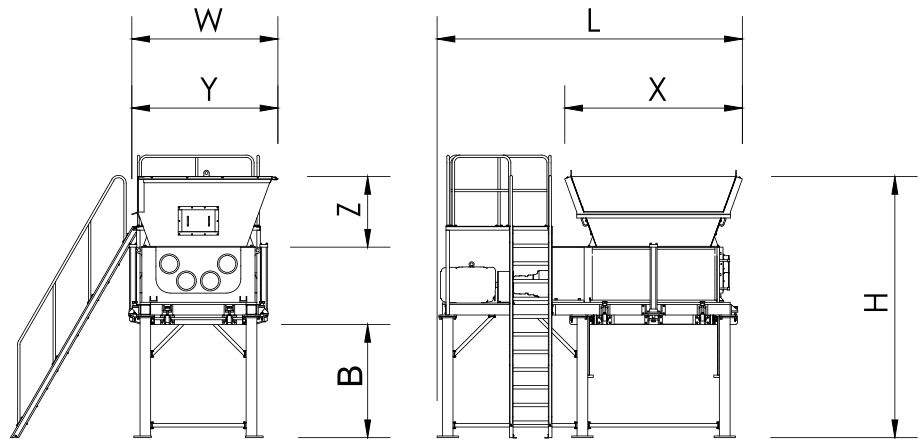

Model	YG-26060	YG-26075	YG-26090
Driver	Motor	Motor	Motor
Q't of motor	2	2	2
Motor Power	20-25 HP(15-18.5kW)	20-25 HP(15-18.5kW)	25-30 HP(18.5-22.5kW)
Total Power	40-50 HP(30-37kW)	40-50 HP(30-37kW)	50-60 HP(37-45kW)
Reduction Ratio	1:60	1:60	1:60
Diameter of Cutter	Φ 260 mm	Φ 260 mm	Φ 260 mm
Material of Cutter	4140	4140	4140
Diameter of Shaft	○100 mm(Hexagonal)	○100 mm(Hexagonal)	○100 mm(Hexagonal)
Thickness of Cutter	20-35 mm	20-50 mm	20-50 mm
Claw Length	22.5 mm	22.5 mm	22.5 mm
Chamber size	610x805x540 mm	760x805x540 mm	910x805x540 mm
Dimension(L*W*H)	2700x1285x2516 mm	2850x1285x2516 mm	3000x1285x2516 mm
Hopper(X*Y*Z)	1300x1250x900 mm	1450x1250x900 mm	1600x1250x900 mm
Discharging Height(B)	1245 mm	1245 mm	1245 mm
Weight	4300 kg	4575 kg	4850 kg
Screen Seat	658x795x595 mm	808x795x595 mm	958x795x595 mm
Screen Weight	361 kg	423 kg	485 kg
Screen Type	Hexagon Screen	Hexagon Screen	Hexagon Screen
Screener Size	Φ 5-50 mm	Φ 5-50 mm	Φ 5-50 mm
Screen moving power	Pneumatic	Pneumatic	Pneumatic
Q't of Cylinder	2	2	2
Screen moving type	Gear Rack	Gear Rack	Gear Rack

- The electrical control box is PLC design.
- Voltage of motor is apply to local voltage.
- The above are standard specification, YungHsing reserves the right to change these specifications without notice.
- For different industry , the design and specification might be modified. Need to refer to the design flowchart for the final specification.
- For other customization and information, please feel free to contact us.



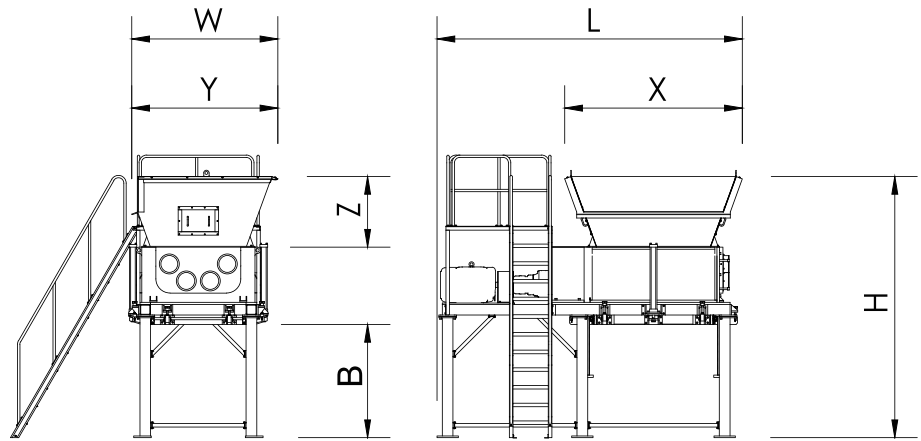

Model	YG-32075	YG-32090	YG-32105
Driver	Motor	Motor	Motor
Q't of motor	2	2	2
Motor Power	25-30 HP(18.5-22.5kW)	30-40 HP(22.5-30kW)	40-50 HP(30-35.5kW)
Total Power	50-60 HP(37-45kW)	60-80 HP(45-60kW)	80-100 HP(60-75kW)
Reduction Ratio	1:60	1:60	1:60
Diameter of Cutter	Φ 320 mm	Φ 320 mm	Φ 320 mm
Material of Cutter	4140	4140	4140
Diameter of Shaft	○115 mm(Hexagonal)	○115 mm(Hexagonal)	○115 mm(Hexagonal)
Thickness of Cutter	25-50 mm	25-50 mm	25-50 mm
Claw Length	35 mm	35 mm	35 mm
Chamber size	760x930x620 mm	910x930x620 mm	1060x930x620 mm
Dimension(L*W*H)	3250x1650x3175 mm	3400x1650x3175 mm	3550x1650x3175 mm
Hopper(X*Y*Z)	1600x1685x1000 mm	1810x1685x1000 mm	1960x1685x1000 mm
Discharging Height(B)	1320 mm	1320 mm	1320 mm
Weight	6419 kg	6842 kg	7265 kg
Screen Seat	816x968x623 mm	966x968x623 mm	1116x968x623 mm
Screen Weight	576 kg	621 kg	666 kg
Screen Type	Hexagon Screen	Hexagon Screen	Hexagon Screen
Screener Size	Φ 5-50 mm	Φ 5-50 mm	Φ 5-50 mm
Screen moving power	Pneumatic	Pneumatic	Pneumatic
Q't of Cylinder	2	2	2
Screen moving type	Gear Rack	Gear Rack	Gear Rack

- The electrical control box is PLC design.
- Voltage of motor is apply to local voltage.
- The above are standard specification, YungHsing reserves the right to change these specifications without notice.
- For different industry , the design and specification might be modified. Need to refer to the design flowchart for the final specification.
- For other customization and information, please feel free to contact us.



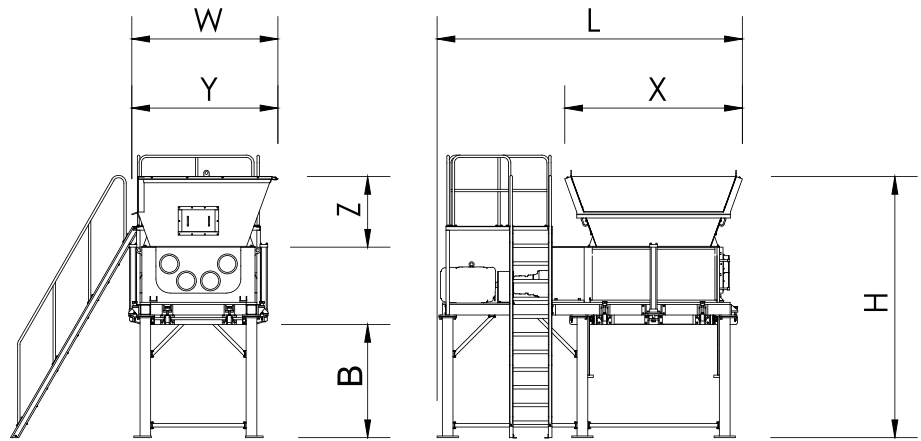

Model	YG-38100	YG-38120	YG-38130
Driver	Motor	Motor	Motor
Q't of motor	2	2	2
Motor Power	40-50 HP(30-35.5kW)	60-75 HP(45-55kW)	75.5-100 HP(55-75.5kW)
Total Power	80-100 HP(60-75kW)	120-150 HP(90-110kW)	150-200 HP(110-150kW)
Reduction Ratio	1:60	1:60	1:60
Diameter of Cutter	Φ 380 mm	Φ 380 mm	Φ 380 mm
Material of Cutter	4140	4140	4140
Diameter of Shaft	○130 mm(Hexagonal)	○130 mm(Hexagonal)	○130 mm(Hexagonal)
Thickness of Cutter	30-50 mm	30-50 mm	30-50 mm
Claw Length	40 mm	40 mm	40 mm
Chamber size	1010x1120x720 mm	1210x1120x720 mm	1310x1120x720 mm
Dimension(L*W*H)	3675x1810x3518 mm	3875x1810x3518 mm	3975x1810x3518 mm
Hopper(X*Y*Z)	1950x1760x1000 mm	2050x1760x1000 mm	2150x1760x1000 mm
Discharging Height(B)	1475 mm	1475 mm	1475 mm
Weight	10600 kg	11200 kg	11500 kg
Screen Seat	1064x1154x798 mm	1264x1154x798 mm	1364x1154x798 mm
Screen Weight	1151 kg	1236 kg	1321 kg
Screen Type	Hexagon Screen	Hexagon Screen	Hexagon Screen
Screener Size	Φ 10-80 mm	Φ 10-80 mm	Φ 10-80 mm
Screen moving power	Pneumatic	Pneumatic	Pneumatic
Q't of Cylinder	2	2	2
Screen moving type	Gear Rack	Gear Rack	Gear Rack

- The electrical control box is PLC design.
- Voltage of motor is apply to local voltage.
- The above are standard specification, YungHsing reserves the right to change these specifications without notice.
- For different industry , the design and specification might be modified. Need to refer to the design flowchart for the final specification.
- For other customization and information, please feel free to contact us.



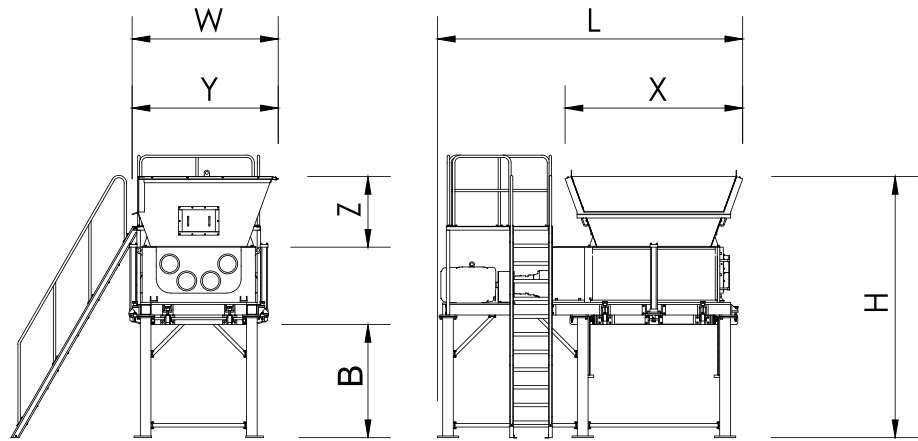

Model	YG-44100	YG-44120	YG-44140
Driver	Motor	Motor	Motor
Q't of motor	2	2	2
Motor Power	75-100 HP(55-75kW)	75-100 HP(55-75kW)	100-125 HP(75-100kW)
Total Power	150-200 HP(110-150kW)	150-200 HP(110-150kW)	200-250 HP(150-200kW)
Reduction Ratio	1:60	1:60	1:60
Diameter of Cutter	Φ 440 mm	Φ 440 mm	Φ 440 mm
Material of Cutter	4140	4140	4140
Diameter of Shaft	○145 mm(Hexagonal)	○145 mm(Hexagonal)	○145 mm(Hexagonal)
Thickness of Cutter	30-50 mm	30-60 mm	35-70 mm
Claw Length	42 mm	42 mm	42 mm
Chamber size	1014x1310x780 mm	1214x1310x780 mm	1414x1310x780 mm
Dimension(L*W*H)	3915x2065x3700 mm	4115x2065x3700 mm	4315x2065x3700 mm
Hopper(X*Y*Z)	2050x1960x1000 mm	2150x1960x1000 mm	2250x1960x1000 mm
Discharging Height(B)	1600 mm	1600 mm	1600 mm
Weight	13360 kg	14210 kg	15060 kg
Screen Seat	1064x1346x808 mm	1264x1346x808 mm	1464x1346x808 mm
Screen Weight	1421 kg	1514 kg	1607 kg
Screen Type	Hexagon Screen	Hexagon Screen	Hexagon Screen
Screener Size	Φ 10-80 mm	Φ 10-80 mm	Φ 10-80 mm
Screen moving power	Pneumatic	Pneumatic	Pneumatic
Q't of Cylinder	2	2	2
Screen moving type	Gear Rack	Gear Rack	Gear Rack

- The electrical control box is PLC design.
- Voltage of motor is apply to local voltage.
- The above are standard specification, YungHsing reserves the right to change these specifications without notice.
- For different industry , the design and specification might be modified. Need to refer to the design flowchart for the final specification.
- For other customization and information, please feel free to contact us.



Shafts and cutters exploded view

YG series quad shredder combines the advantages of traditional shredder and crusher to be an extreme shredder. The application could be break-up to the final size directly with the screener. This is the exploded view of shafts and cutters, the feature is <Unidirectional dismantle>.

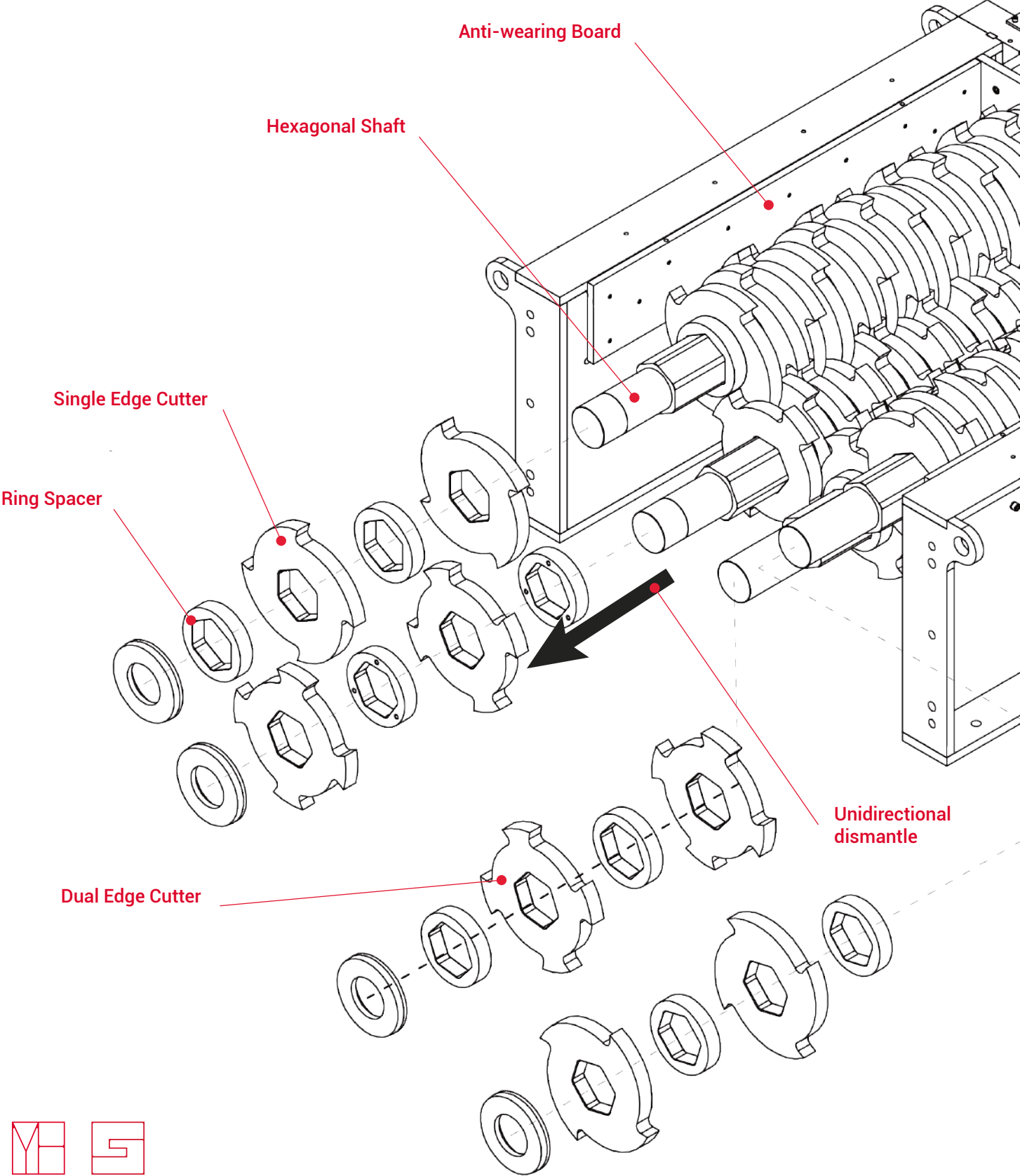

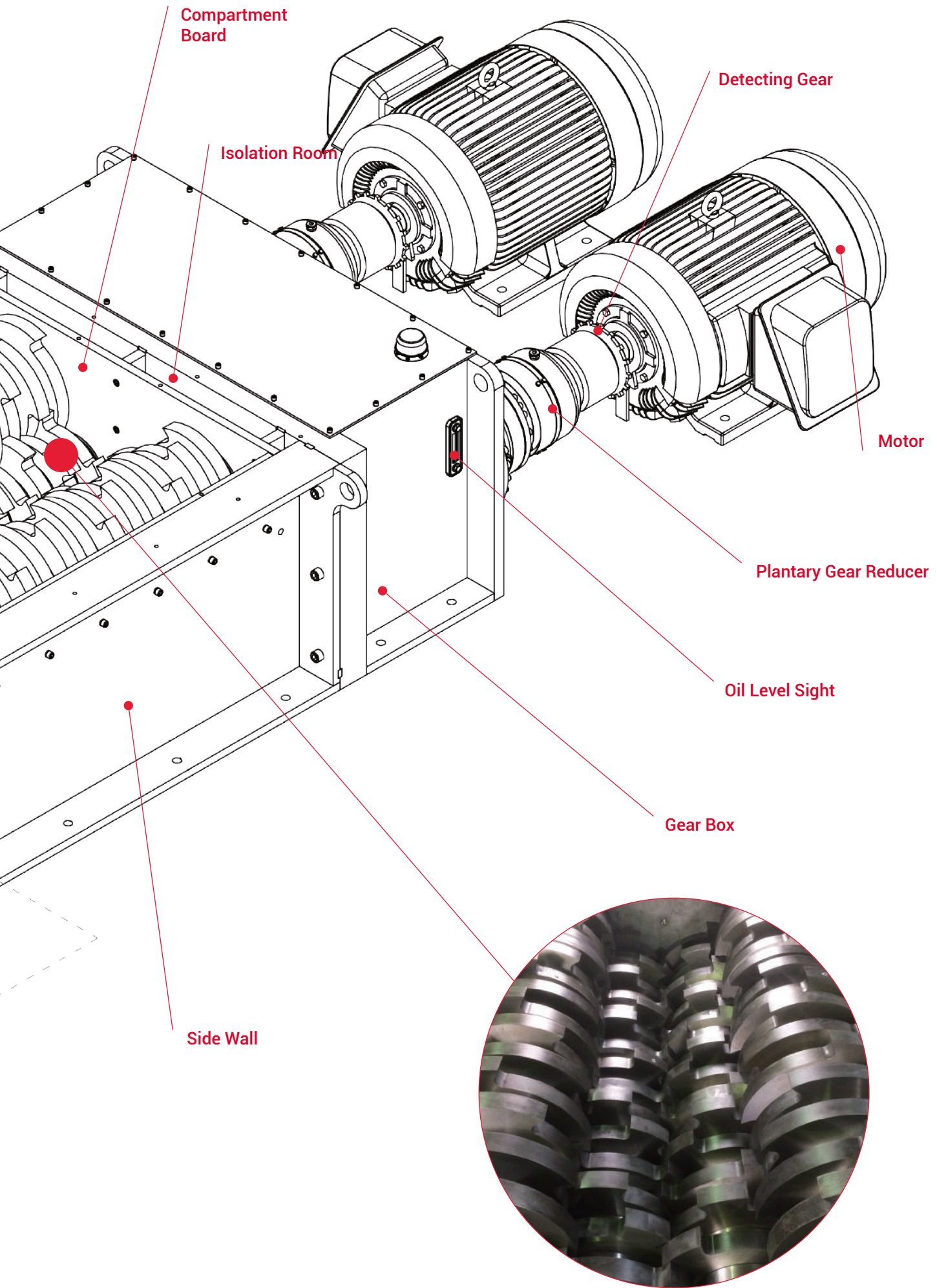

YG Series

Product features

YG Series Quad Shredder is a powerful machine, eliminate the disadvantages in traditional crusher to low-noise and long-time working. Especially for the unusual objects, bakelite, woods, wires & cables, rubbers, aluminum cans etc...To associate the screeners is able to reach the final size as requirement directly.

- Quad Shredder — p.11-12
- Product photos — p.13-16
- Reference photos — p.17-18

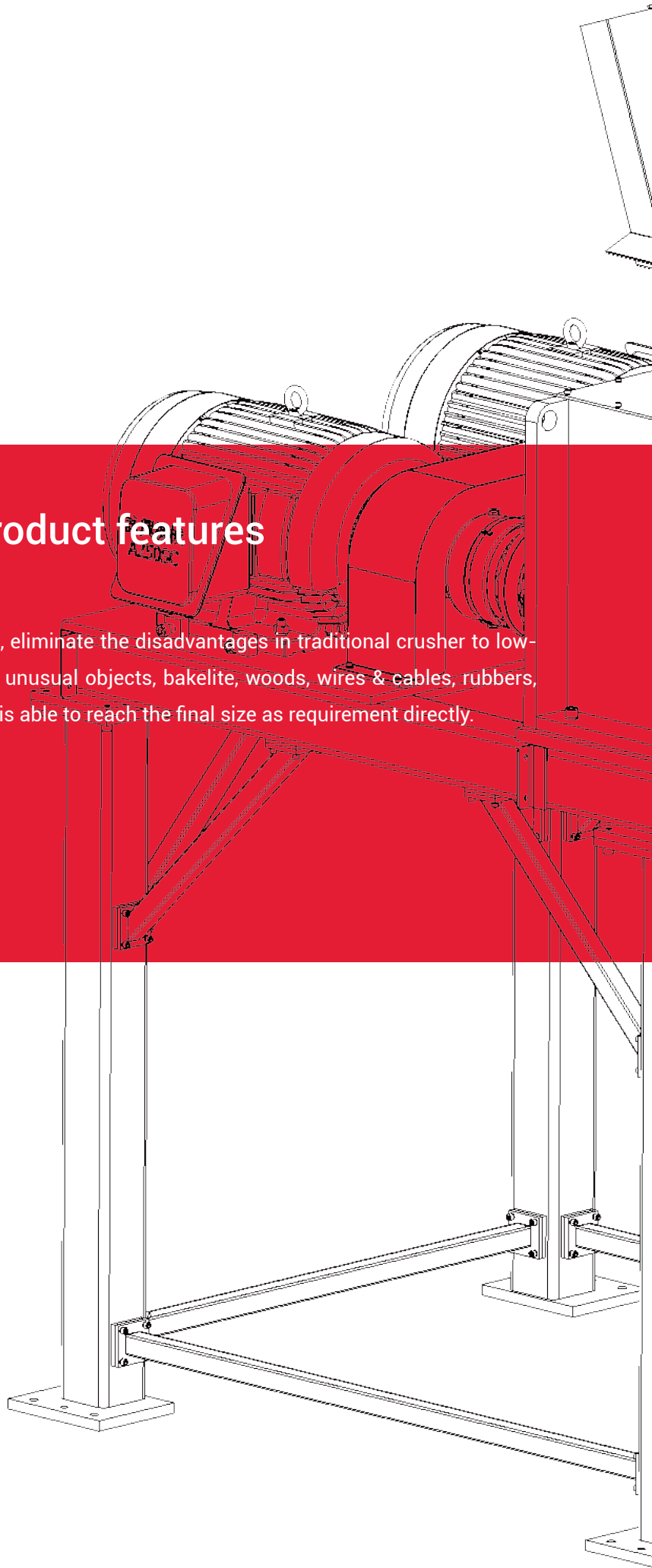

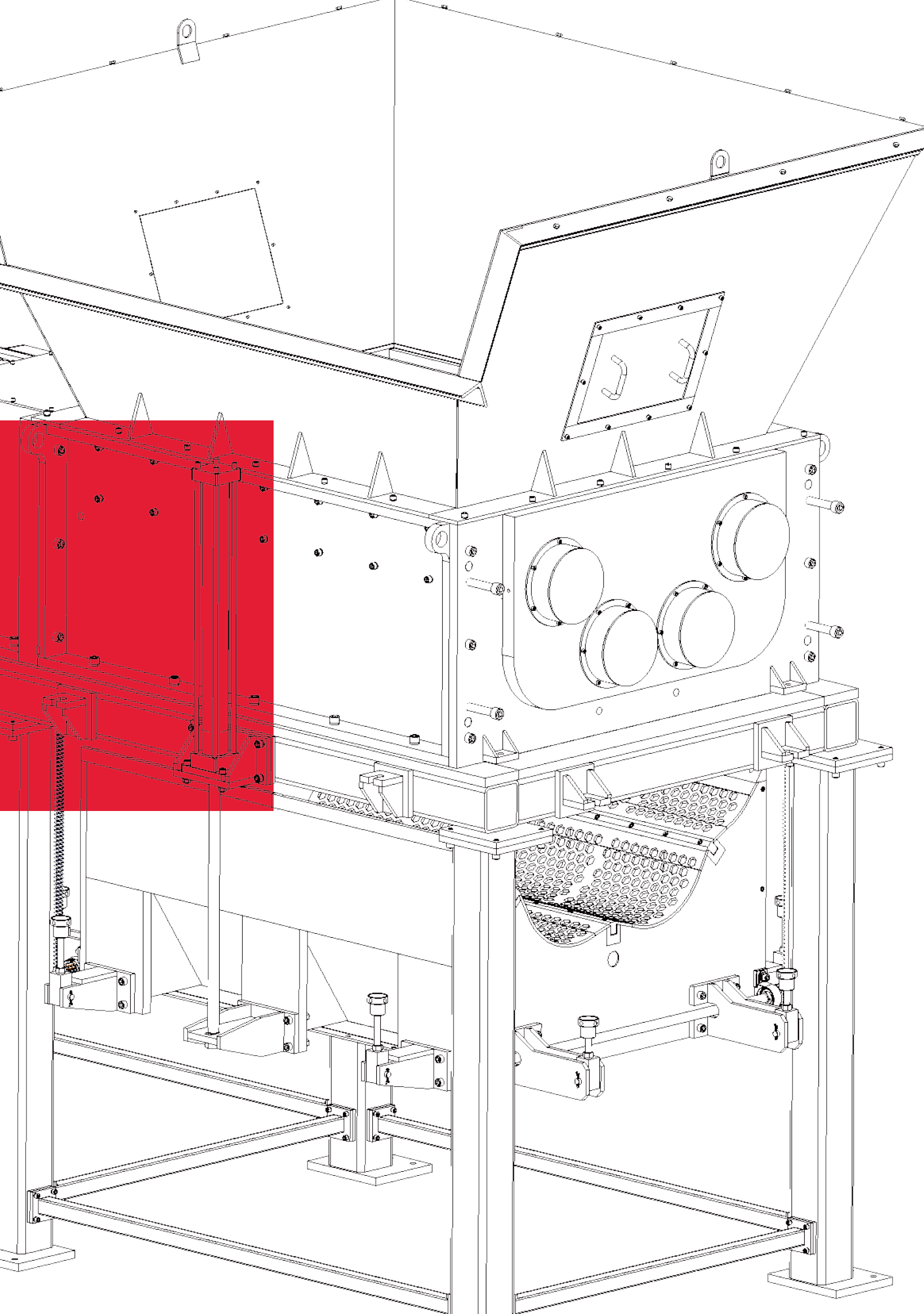

1 Quad shafts design \ Hexagonal shaft \ Multi-claws cutters are able to break up the application with the extremely shredding power.

2 Cutter is made of special alloy steel with the heat-treatment, durable, re-weldable, and easy to change piece-by-piece.

3 Power driving is from the motor connecting through the planetary gear to gear box, the advantage is low-speed, less dusting, high- torque, power-shredding.

4 The transmission gear is made of special alloy steel with the heat-treatment. Gear box is using oil bath lubrication which is smooth, low-noise, and long time working.

5 Hexagonal screener is able to increase the capacity up. The moving is using pneumatic (Or hydraulic)lifting with the gear rack which is stable and smooth.

1 QUAD SHRE FEATU



AD DDER URES

6

The upper two shafts are able to grab and break-up. The lower two shafts are dual-edged cutters. Three are three breaking lines in shredding.

7

Clamp plates, locking outer ring, and back-side plate are design to multi-locking and encure the cutters working functionally.

8

Without dismantling shaft, gear, reducer, and motor it can replace of cutters and space rings for the maintenance.

9

Easy to break up the softs, hardness, and toughness applications. Gearbox and rear wall are designing of the separation. The chamber is allow to be washable.

10

In case of clog out and prevent motor to overloaded, the machine will set up a reversal rotation by electric control system. It is still breaking up in revesal rotation.

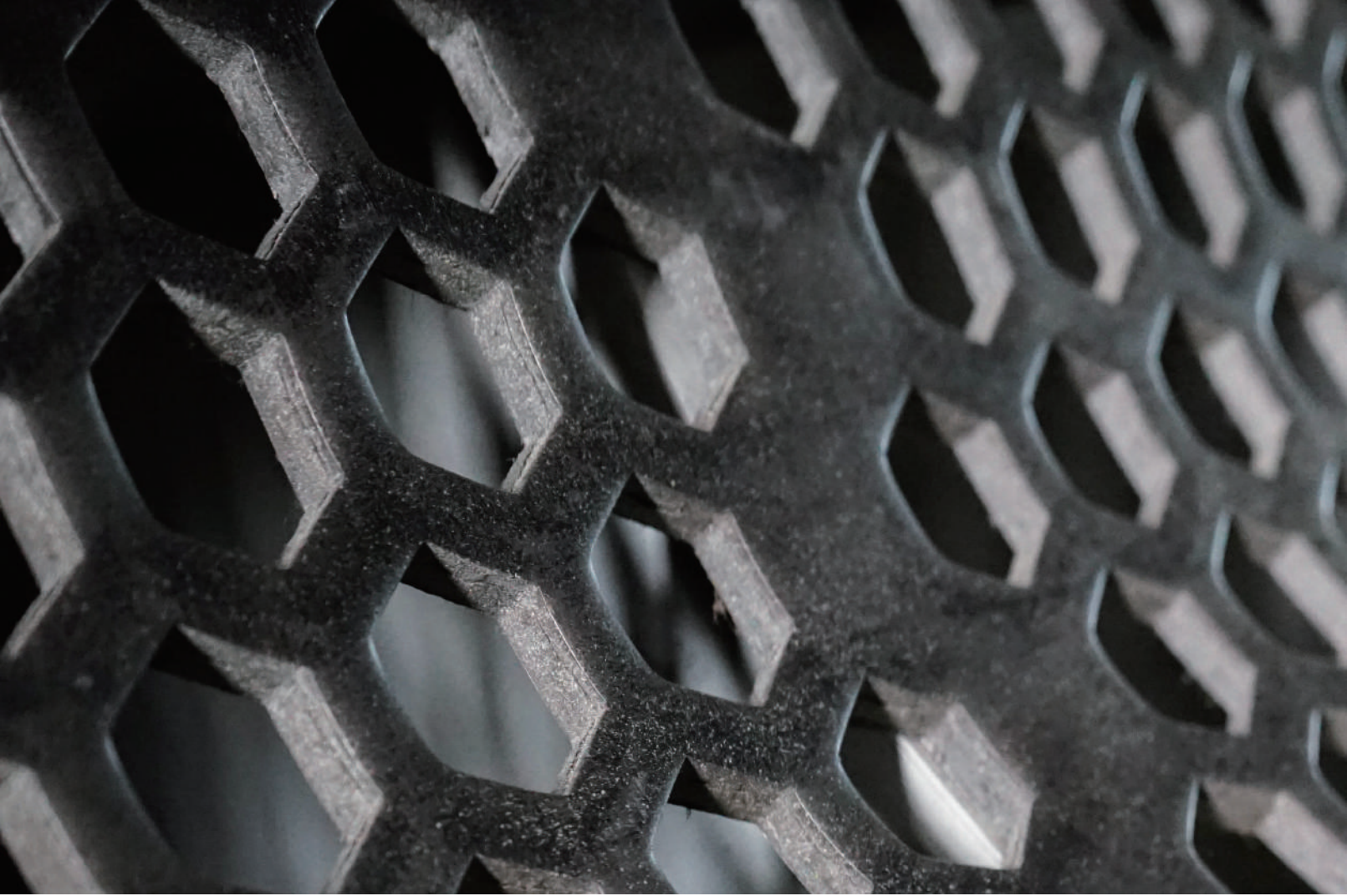

①

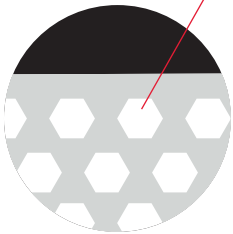

②

① Hexagon screen(close-up view)

② Hexagon screen(whole body)



3

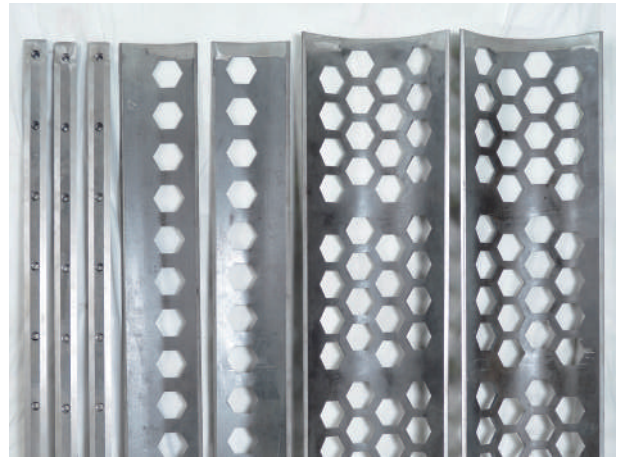

4

3 Screen lifting on 4 lines of gear rack

4 Hexagon screen (parts explosion)



5



6



7

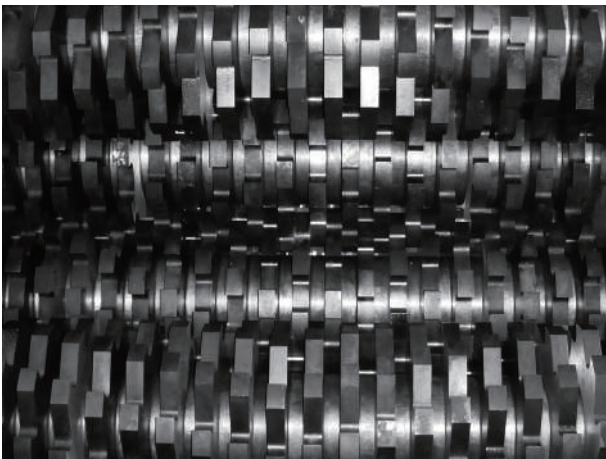
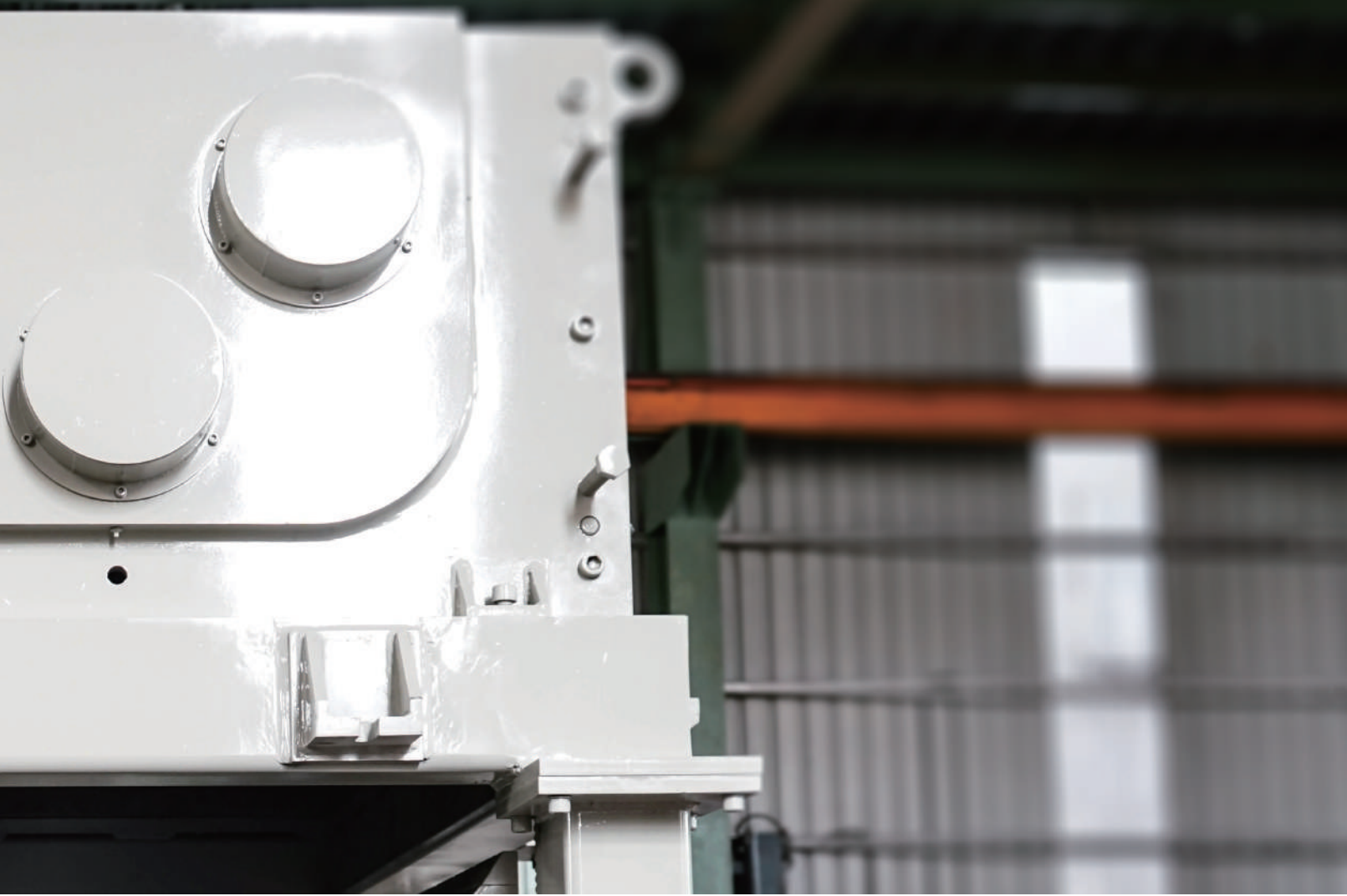

⑧

⑤ Chamber room (front view)

⑥ Four sets of cutters

⑦ Cutters \ Shafts

⑧ Cutters (top view)

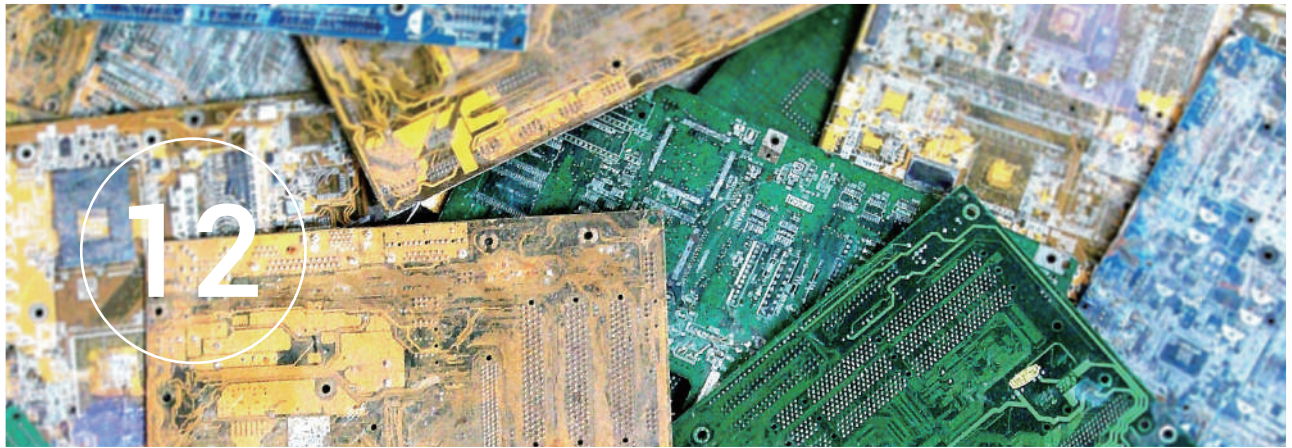
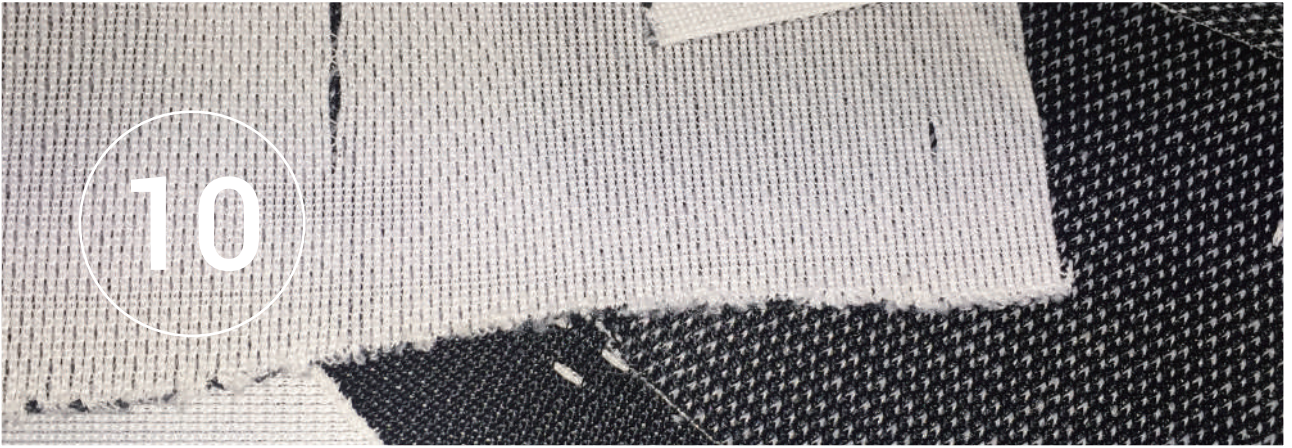

Raws Materials

Reference photos

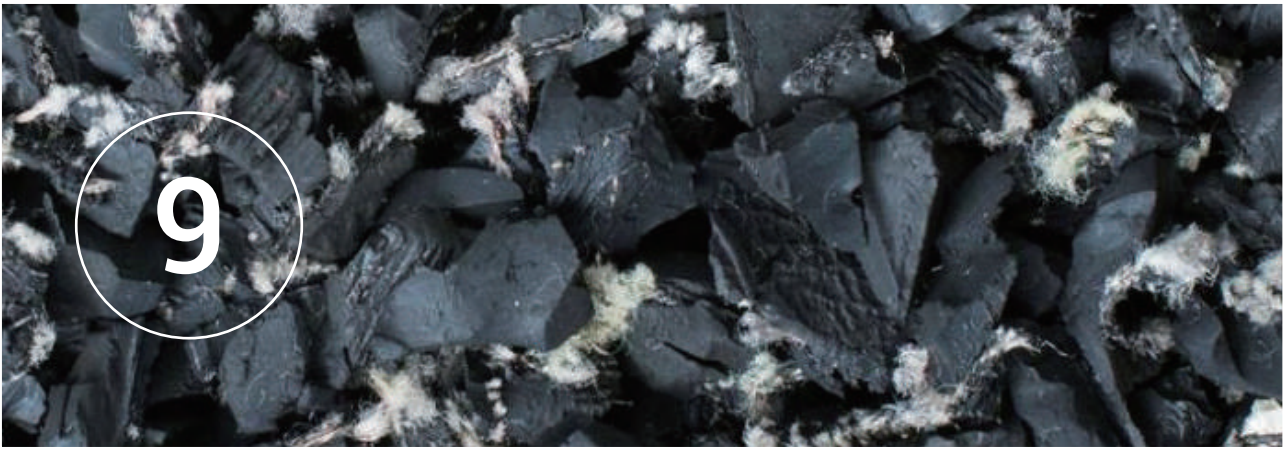

Discharging product

Reference photos

⑨ Tires 、 Rubbers

⑪ Woods 、 Pallets

⑩ Textiles

⑫ PCB Board

YG Series

Customization

YG Series Quad Shredder is a powerful machine, eliminate the disadvantages in traditional crusher to low-noise and long-time working. Especially for the unusual objects, bakelite, woods, wires & cables, rubbers, aluminum cans etc...To associate the screeners is able to reach the final size as requirement directly.

■ Customized device — p.22-23

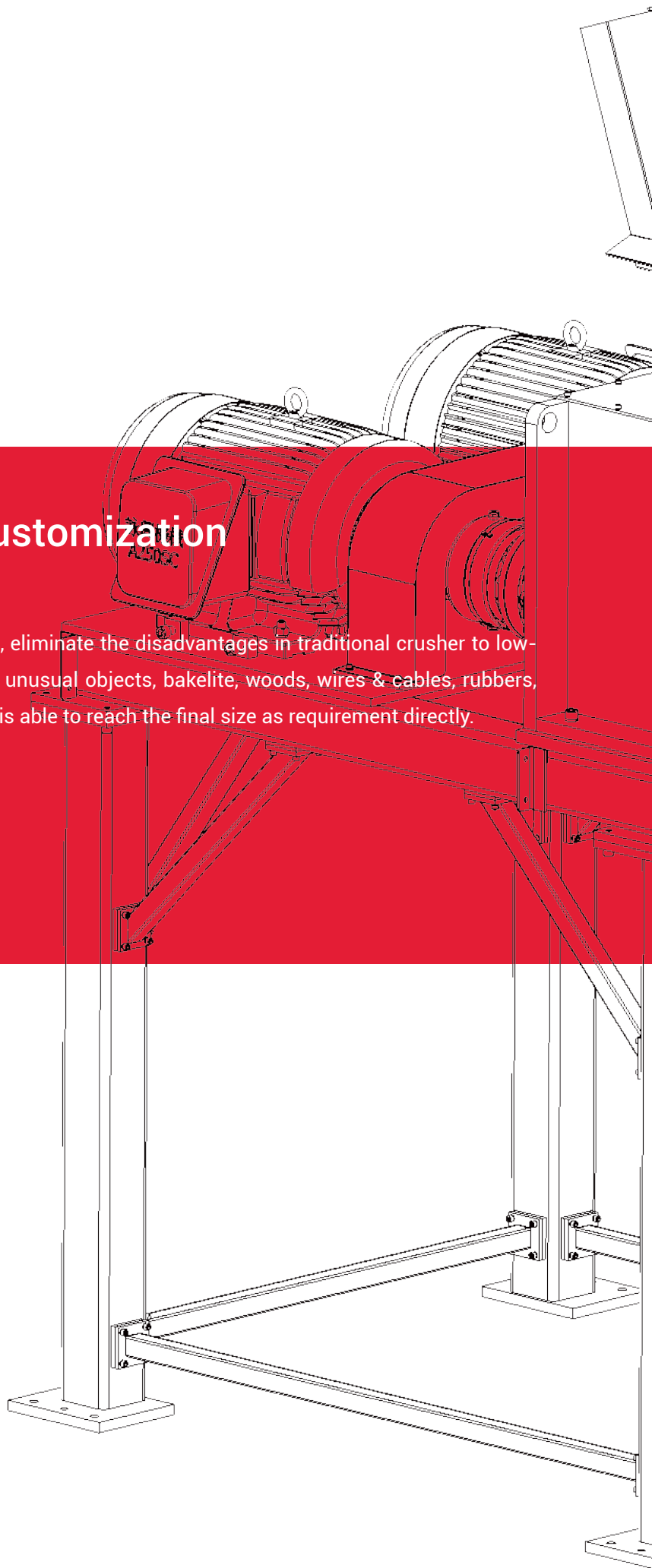

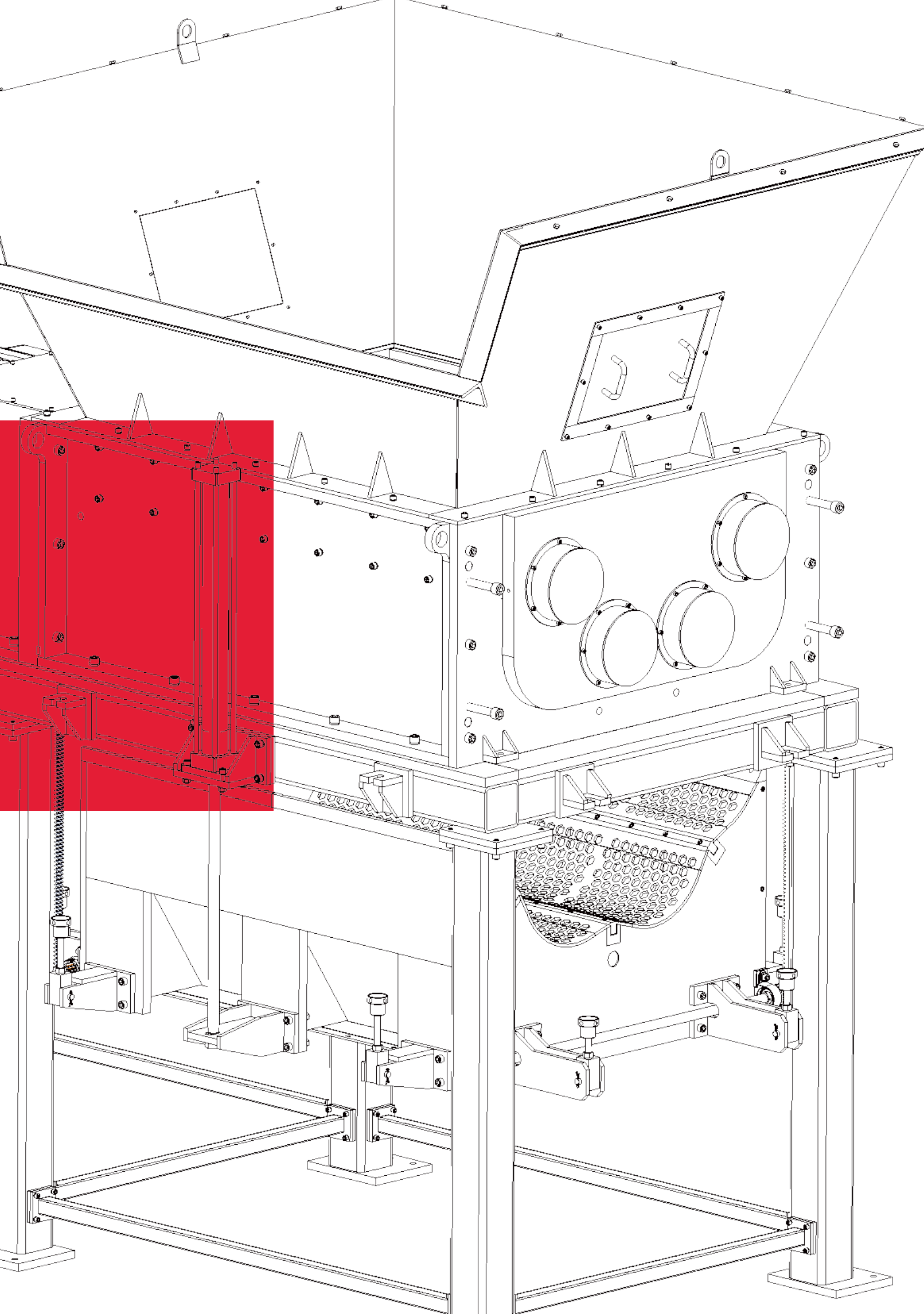

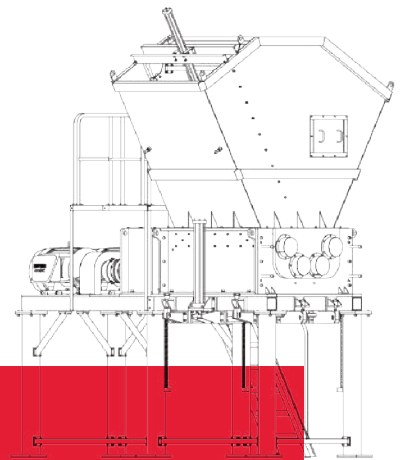
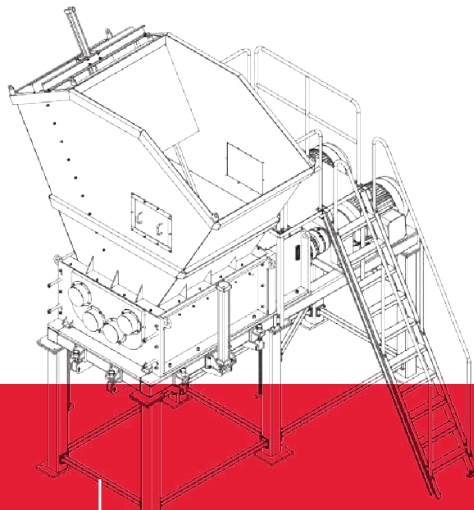
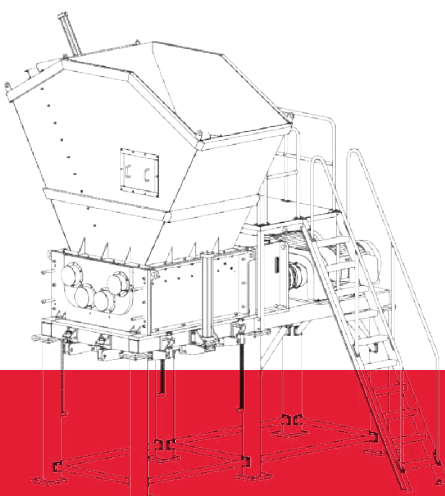
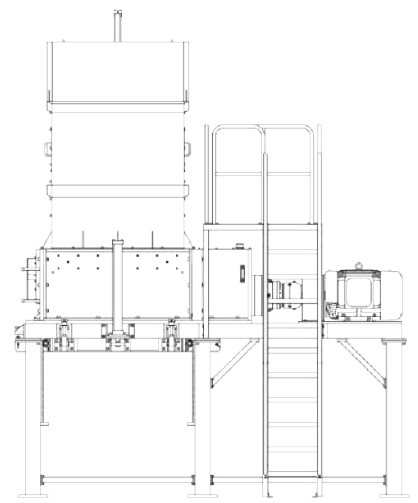
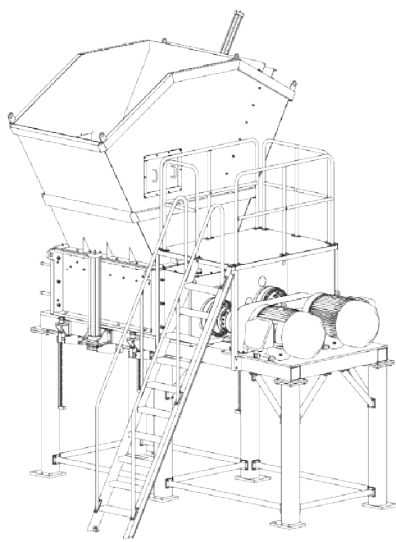
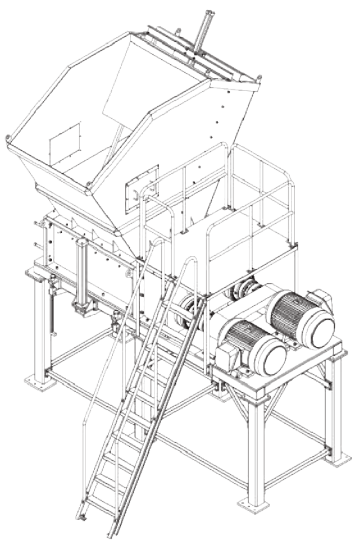

Customized device

Hydraulic Feeding Hopper

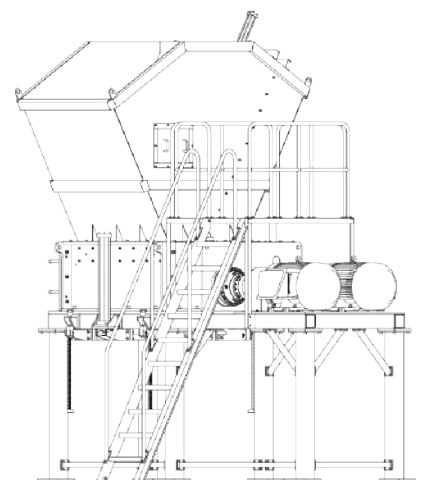
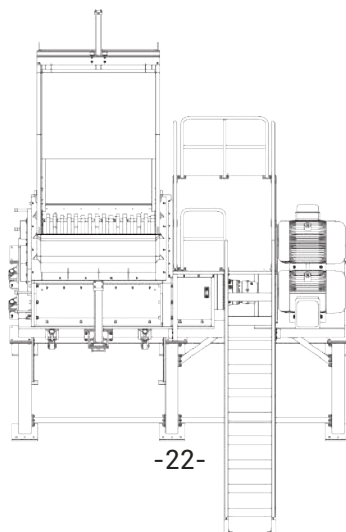
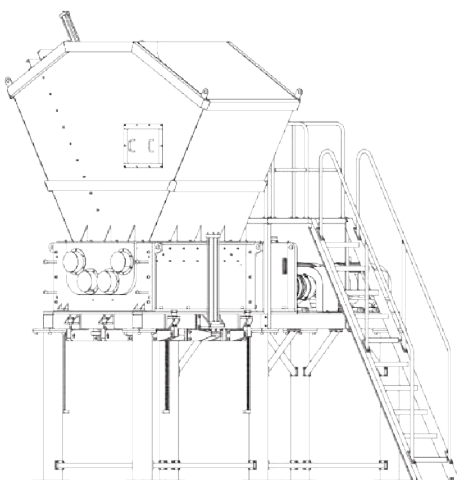
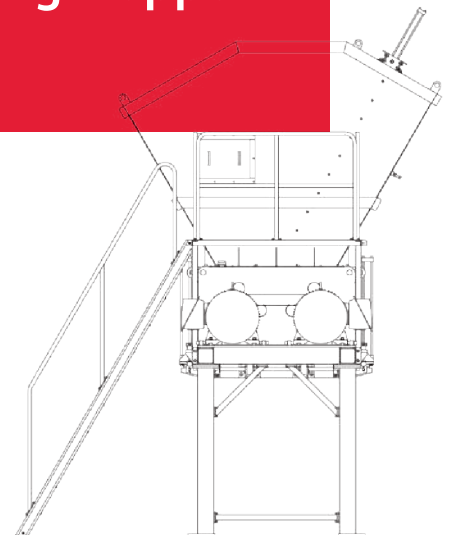
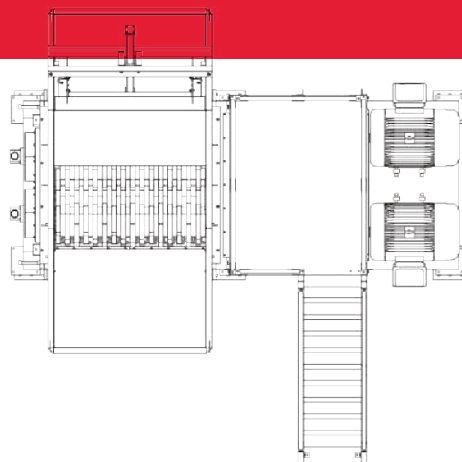
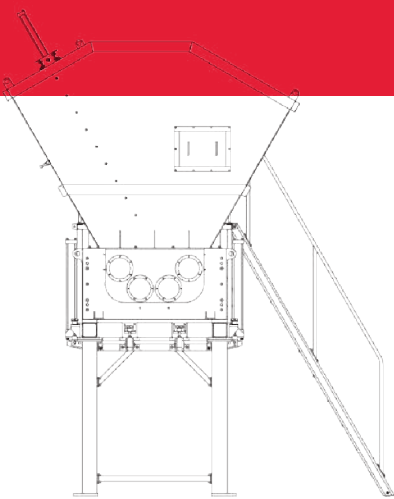

Model	YG-26060	YG-26075	YG-26090
Oil Cylinder	HOBΦ50-Φ30-1000ST-TC		
Power	3HP-4P-Φ3		
Pump Flow	15 L/MIN		
Pipe	3/8		
Stroke	800 mm		

Model	YG-32075	YG-32090	YG-32105
Oil Cylinder	HOBΦ50-Φ30-1000ST-TC		
Power	3HP-4P-Φ3		
Pump Flow	15 L/MIN		
Pipe	3/8		
Stroke	1000 mm		

Model	YG-38100	YG-38120	YG-38130
Oil Cylinder	HOBΦ50-Φ30-1000ST-TC		
Power	3HP-4P-Φ3		
Pump Flow	15 L/MIN		
Pipe	3/8		
Stroke	1000 mm		

Model	YG-44100	YG-44120	YG-44140
Oil Cylinder	HOBΦ50-Φ30-1000ST-TC		
Power	3HP-4P-Φ3		
Pump Flow	15 L/MIN		
Pipe	3/8		
Stroke	1000 mm		

- The above are standard specification, YungHsing reserves the right to change these specifications without notice.
- For different industry , the design and specification might be modified. Need to refer to the design flowchart for the final specification.
- For other customization and information, please feel free to contact us.





詠興機械工業有限公司 | 詠固精密機械有限公司

831 高雄市大寮區三隆里光華路 470 巷 196 號

No.196, Ln. 470, Guanghua Rd., Daliao Dist., Kaohsiung City 831, Taiwan

Tel. +886-7-7878275 **Fax.** +886-7-7883641 **Mobile.** +886-972-318-166 **Hot Line.** +886-7-7873262

Mail. yg.machine@hotmail.com (Domestic) yunghsingsh@gmail.com (International)

■ **Professional manufacturer – Equipment**

Twin Shaft Shredder, Quad Shaft Shredder, Powerful Crusher, Hammer-Mill to powder, Degumming & Separating machine for waste tire, Hammer-Mill, Extruding Automatic Recycle Crusher, Gravity Separator, Paralleled Blow Screener, Eddy Current, Vibrating Separator, Dust Collection Equipment, Other Equipment made by Customer requirements.

■ **Professional manufacturer – Whole Plant**

Municipal Solid Waste, Laminate Glass, Waste Glass, PCB (Components), Waste Wire & Cable, Waste Tires, Waste Wooden, Garbage, Electrical Control Box, Waste Plastics, Waste Hardware, Waste Battery, Other waste material for whole plant equipment

